



Outdoor Air Static Pressure Pickup Port Vertical Mount

Installation and Operating Instructions

19047_ins_zps_acc_out_pickup_v

Rev 05/29/2007

How It Works

Building static pressure is the pressure difference between the inside and the outside of a building. The outdoor static pressure is simply the atmospheric pressure at the building site. The building may have positive, neutral or negative pressure with respect to the outside atmosphere. Differences in pressure are due to powered supply or exhaust fans and are usually less than 0.1 inches of water.

A complication in measuring the building static pressure is the dynamic action of the wind. A gentle breeze of 10 MPH provides a pressure of 0.048 inches of water, a gale of 40 MPH is 0.772 inches and a hurricane of 75 MPH is 2.716 inches. Clearly, the wind's pressure may be more than the desired building static pressure. Measuring the wind's pressure instead of the true outdoor static pressure will radically alter the actual static pressure reading. Mounting the unit with the plate parallel to the earth's surface, as shown in Figure 2 allows the predominantly horizontal flow of the wind an omni-directional entry between the plate and the housing. The plate forces the wind to move perpendicularly to the pressure orifice in the housing, irrespective of the wind's direction, greatly minimizing the dynamic air pressure.

The BA/ACC10-V was developed to mount to the soffit of a building or to ceilings where other pressure pickups are not desired.

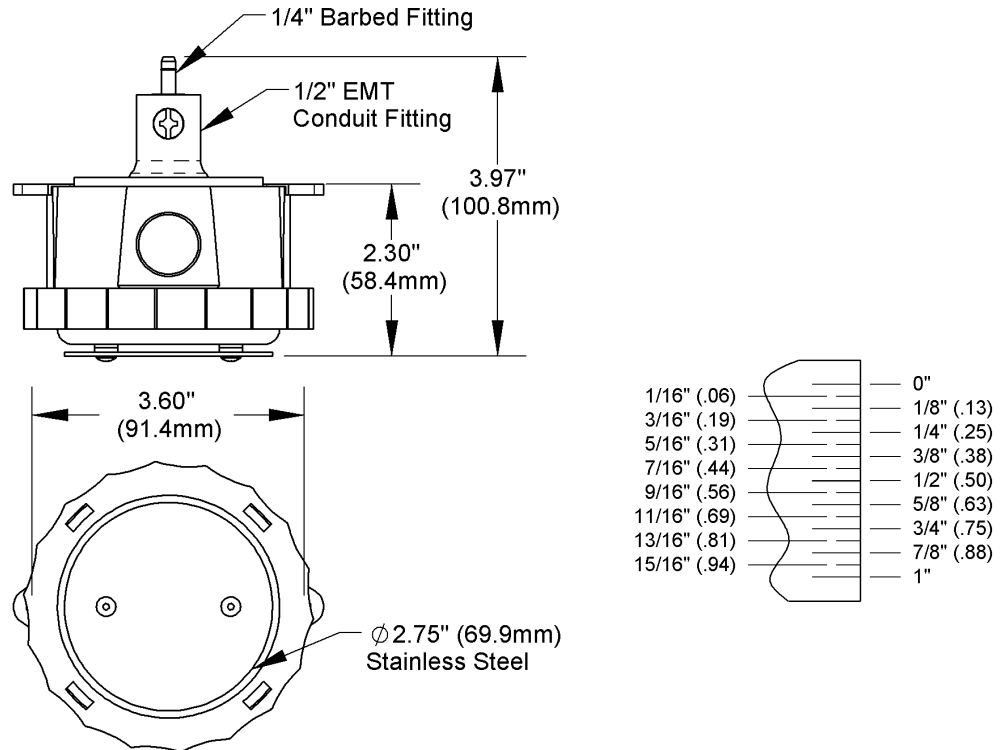

Figure 1: BAPI Outdoor Air Static Pressure Pickup, Vertical Mount

Tools and Materials

#2 Philips Screwdriver, #8 screws, Drill, 1 ¼ inch hole saw, 1/8 inch drill, ½ inch EMT conduit (if needed).

Specifications subject to change without notice.

Mounting

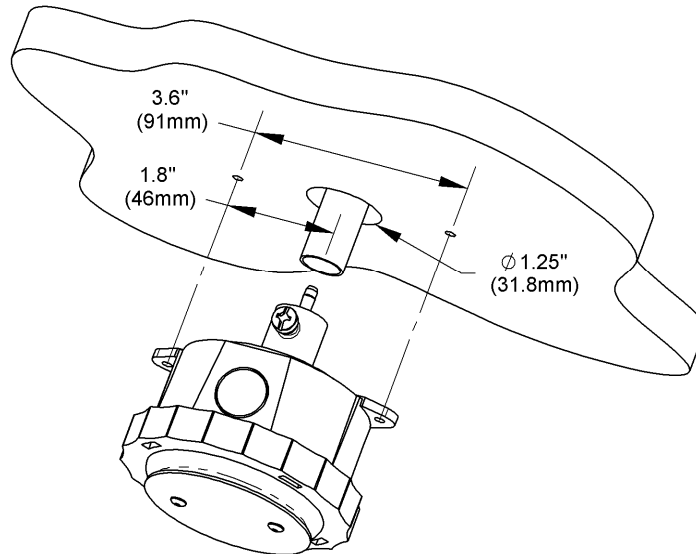

Figure 2: Outdoor Air Static Pressure Pickup Port Mounting.

Outdoors, do not mount within 48 inches of economizers, intake or exhaust fans, or barometric dampers. Mount near the center of the building on the side of the building away from the predominant wind. Mount at least 24 inches from the wall.

Indoors, do not mount within 48 inches of diffusers, circulating fans or return grills. Mount near the center of the space to be monitored. Do not mount in a closet or other confined space.

Conduit may or may not be used.

Conduit

Drill a 1 ¼ inch hole at the position you wish to mount the pickup. If using conduit, thread the pressure tubing through the conduit. Leave the conduit loose with at least 1 inch protruding from the 1 ¼ inch hole. Attach the pressure tubing to the barbed fitting inside the conduit fitting on the pickup port. Slide the conduit into the conduit fitting and secure the conduit with the screw in the pressure port's conduit fitting. Push the pickup port against the surface and mark the mounting holes. Drill the mounting holes with a 1/8 inch drill. Mount the unit with #8 screws. Attach the far end of the conduit and connect the pressure tube to your pressure sensor. BAPI recommends the ZPS Differential Pressure Transmitter for the pressure sensor.

No Conduit

Drill a 1 ¼ inch hole at the position you wish to mount the pickup. Attach the pressure tubing to the barbed fitting inside the conduit fitting on the pickup port. Push the pickup port against the surface and mark the mounting holes. Drill the mounting holes with a 1/8 inch drill. Mount the unit with #8 screws. Connect the pressure tube to your pressure sensor. BAPI recommends the ZPS Differential Pressure Transmitter for the pressure sensor.